

TC-9D / TC-10D / TC-12D

Towmaster's TC-series provides the perfect value combining the features you need with the quality a Towmaster built trailer offers. This model works well for skid-loaders, mini-excavators and other small equipment. The TC drop-deck is built on a solid cold-formed one-piece I-beam frame with 3-inch I-beam crossmembers and treated pine wood deck. It includes Dexter® Torflex® rubber torsion axles, bolt-on parking jack, and solid-bar ramp hold-ups.

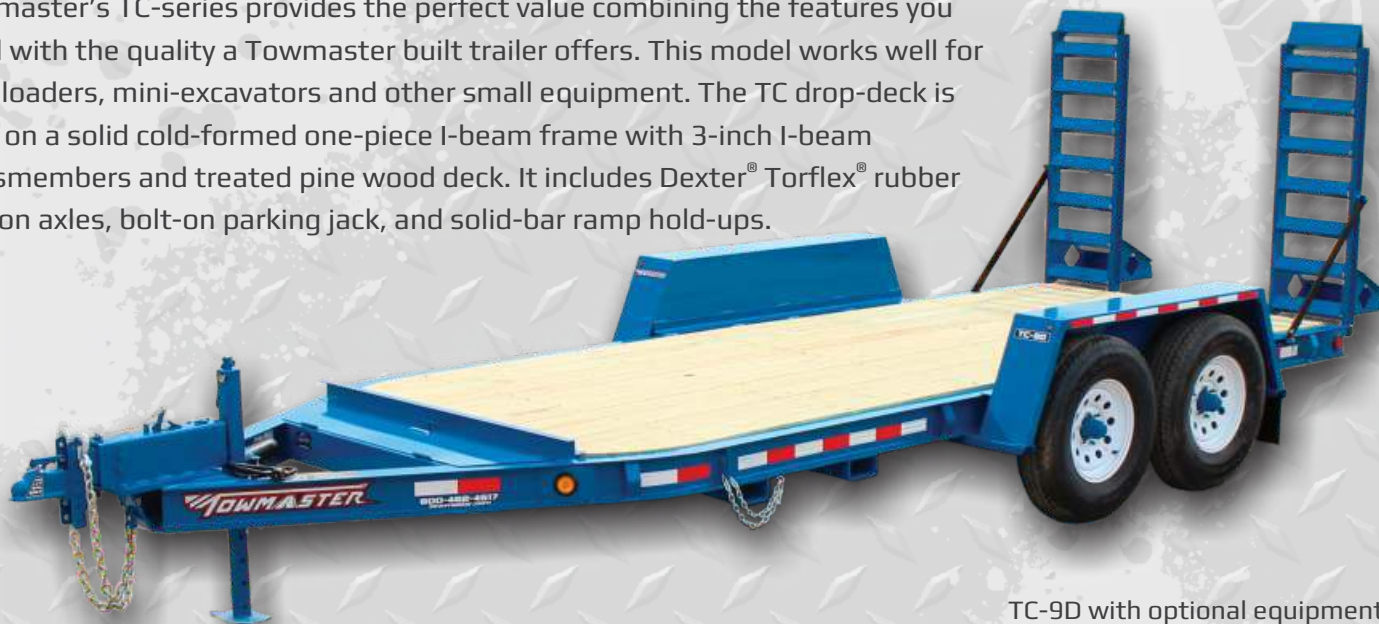

TC-9D with optional equipment shown



Formed frame and tongue provide a strong and integral structure for the trailer.



Sealed battery break-away system charges while plugged into the tow vehicle and can be checked at the press of a button.



Heavy-duty one-piece formed fender with backing plate keeps tire debris off equipment.

Quick Specs:

- 2" nom. treated pine deck*
- 14', 16', 18', or 20' deck
- One-piece formed fender/inner panel
- 17.5"-21.5" deck height (loaded)
- Dexter® Torflex® axles
- Solid bar ramp hold-ups
- 82" between fenders
- Forward adjusting elec. brakes
- Grommet mounted LED lights

*oak deck on TC-14D

Photos may show optional equipment.



AMERICA'S BEST BUILT TRAILERS FOR PROFESSIONAL HAULERS



800-462-4517
TOWMASTER.COM

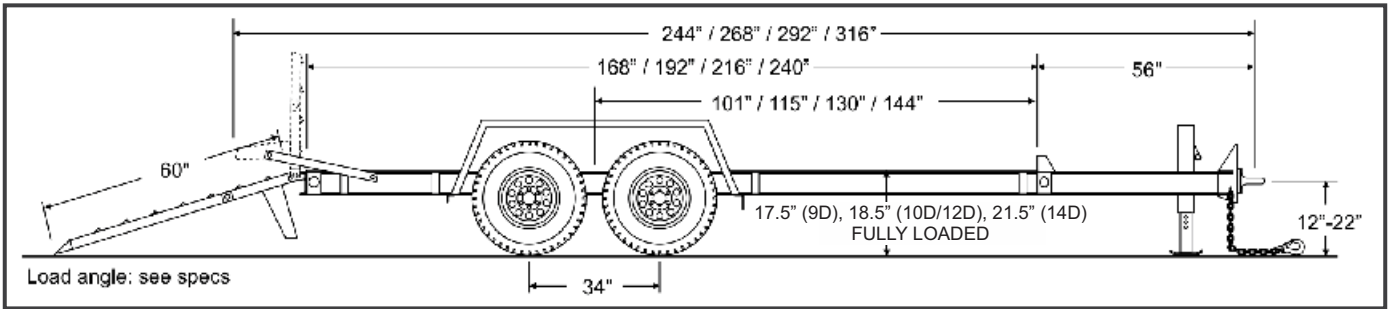

MORE MODELS • MORE OPTIONS • MORE CHOICES
DROP-DECK • TILT BED • DECK-OVER • GOOSENECK • LOWBOY • HYDRAULIC TAIL

SPECIFICATIONS

S=Standard O=Optional

CAPACITY / DIMENSIONS	TC-9D	TC-10D	TC-12D	TC-14D
Approx. Payload (lbs/kg)	7,390 / 3352	10,000 / 4536	12,000 / 5443	14,000 / 6350
GVWR (lbs/kg)	9,990 / 4531	12,600 / 5715	14,600 / 6622	16,600 / 7530
GAWR (lbs/kg)	12,000 / 5443	12,000 / 5443	12,000 / 5443	14,000 / 6350
Approx. Avg. Weight (lbs/kg)	2,600 / 1179	2,600 / 1179	2,600 / 1179	2,700 / 1225
Overall Length – 14' (ft-in/mm)	20-4 / 6198	20-4 / 6198	20-4 / 6198	N/A
Overall Length – 16' (ft-in/mm)	22-4 / 6807	22-4 / 6807	22-4 / 6807	22-4 / 6807
Overall Length – 18' (ft-in/mm)	24-4 / 7417	24-4 / 7417	24-4 / 7417	24-4 / 7417
Overall Length – 20' (ft-in/mm)	26-4 / 8027	26-4 / 8027	26-4 / 8027	26-4 / 8027
Deck Height (loaded)(in/mm)	17.5 / 445	18.5 / 470	18.5 / 470	21.5 / 546
Overall Width (ft-in/mm)	8-6 / 2591	8-6 / 2591	8-6 / 2591	8-6 / 2591
Load Width (in/mm)	82 / 2083	82 / 2083	82 / 2083	82 / 2083
TONGUE				
Tongue Length 5'-0" (1524mm)	S	S	S	S
One-Piece Cold-Formed Tongue / Frame	S	S	S	S
Pintle Ring (in)	2.5	2.5	2.5	3
High-Tensile Safety Chain	3/8" Grade 43	3/8" Grade 43	3/8" Grade 43	3/8" Grade 70
Bolt-on Drop-Leg Parking Jack	7K	7K	7K	12K
FRAME / RAMPS				
Main Beam	6" I-Beam	6" I-Beam	High-Tensile W6 x 12	High Tensile W8 x 10
Crossmembers	3" Jr I-beam	3" Jr I-beam	3" Jr I-beam	3" Jr I-beam
Headboard Height (in / mm)	3 / 76	3 / 76	3 / 76	3 / 76
Deck Lip	N/A	N/A	N/A	N/A
Deck Material	2" nom. Treated Pine	2" nom. Treated Pine	2" nom. Treated Pine	2" nom. White Oak
12 ga. One-piece formed fenders and inner panel	S	S	S	S
Ramps (Ladder Style) Length x Width (ft-in x in/mm)	5-0x18 / 1524x470	5-0x18 / 1524x470	5-0x18 / 1524x470	5-0x18 / 1524x470
Load Angle (degrees)	17	17	17	19
Ramp Spring-Assist	O	O	O	O
Ramp Hold-ups	Solid Bar	Solid Bar	Solid Bar	Solid Bar
Tie Downs	Integrated Formed	Integrated Formed	Integrated Formed	Integrated Formed
Number of Tie-Downs (Total / Side)	8 / 4	8 / 4	8 / 4	8 / 4
SUSPENSION / TIRES				
Rubber-Ride Axles w/Warranty	S	S	S	S
Axle Capacity (each) (lbs/kg)	6,000 / 2721	6,000 / 2721	6,000 / 2721	7,000 / 3175
Axle Spread (in/mm)	34 / 864	34 / 864	34 / 864	34 / 864
Hubs	Standard Lube	Standard Lube	Standard Lube	Standard Lube
Electric Brakes w/Forward Adjust	S	S	S	S
Brake Size (in/mm)	12x2 / 305x51	12x2 / 305x51	12x2 / 305x51	12x2 / 305x51
Battery Break-Away Kit with Tow Charger	S	S	S	S
Wheels (in/mm)	15x6 / 381x152	16x6 / 406x152	16x6 / 406x152	16x6 / 406x152
Wheel Bolt Pattern	6-bolt	6-bolt	6-bolt	8-bolt
Tires / Load Range Rating	ST225/75R15 / D	235/85R16 / E	235/85R16 / E	235/85R16 / E

STANDARD EQUIPMENT

- Adjustable hitch height
- RV electrical plug
- Weather resistant sealed modular wiring
- Grommet mounted LED lights
- Registration holder
- Rust inhibiting primer
- Durable, rust inhibiting top coat
- Die-cut UV resistant vinyl decals
- D.O.T. approved conspicuity tape
- Mud flaps
- Adjustable ramp width spacing
- Trailer color: Equipment black
- Ramp color: Equipment red

OPTIONAL EQUIPMENT

- Hydraulic surge brakes
- 3" pintle ring or 2-5/16" ball coupler
- Gooseneck hitch
- 12K parking jack
- 6-pole round electrical plug
- Storage tray lid
- Pallet fork holders
- 8K electric winch
- Additional tie-downs
- D-ring tie downs
- 3 ft. beavertail (with 4 ft. ramps)
- E-Z Lube hubs
- Spare tire and wheel / mount
- Tire upgrades
- Ramp lift springs
- Auto-Latch ramps
- Several ramp options available
- Color options: Construction Yellow, Equipment Red, Blue, Charcoal
- Galvanizing



Other options may be available. Ask your dealer or visit our website.

*Payload capacity is calculated by taking the GVWR and subtracting the trailer weight.
Listed GVWR, weights, and dimensions are for reference only. Manufacturer reserves the right to change models and specifications as they see fit. See our web site or your local authorized dealer for more information.