



This economical trailer is great for mid-sized equipment. Built on the Towmaster® I-beam frame, this trailer features 3-inch I-beam crossmembers, 8'-6" wide deck, 5-foot angle-iron beavertail and 5-foot one-way spring assist ramps. The TC-16 is a single-wheel twin axle trailer. Sealed wiring and grommet mounted LED lights are standard.



Single-wheel tandem axle. 8K axles with spring-ride suspension.



Angle-iron beavertail and ramps provide excellent traction for loading and unloading.



One-way spring-assist ramps and grommet mounted LED lights.

Quick Specs:

- 33" deck height (loaded)
- 8'-6" deck width
- 20' deck length
- Electric brakes
- D-ring tie-downs
- Spring suspension
- 5' angle-iron beavertail
- One-way spring-assist ramps
- LED lights



Photos may show optional equipment.

AMERICA'S BEST BUILT TRAILERS FOR PROFESSIONAL HAULERS



800-462-4517
TOWMASTER.COM



MORE MODELS • MORE OPTIONS • MORE CHOICES
DROP-DECK • TILT BED • DECK-OVER • GOOSENECK • LOWBOY • HYDRAULIC TAIL

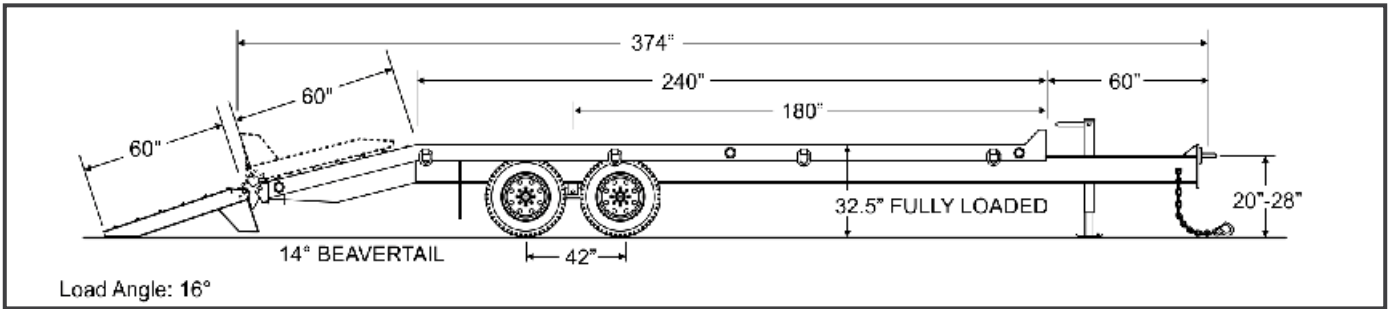

SPECIFICATIONS

S=Standard O=Optional
TC-16

CAPACITY / DIMENSIONS

Capacity Rating (lbs/kg)	16,000 / 7258		
GVWR (lbs/kg)	21,900 / 9934		
GAWR (lbs/kg)	16,000 / 7257		
Approx. Weight (lbs/kg)	5,900 / 2676		
Deck Length (ft-in/mm)	20-0 / 6096		
Overall Length (ft-in/mm)	31-2 / 9500		
Deck Height (loaded)(in/mm)	32.5 / 826		
Overall Width (ft-in/mm)	8-6 / 2591		

TONGUE

Tongue Length (ft-in/mm)	5-0 / 1524		
Storage Tray	S		
Storage Tray Lid	O		
Pintle Ring (in)	3"		
High-Tensile Safety Chain (size - in)	3/8 Grade 70		
Bolt-on Drop-Leg Parking Jack	12K		

FRAME / RAMPS

Main Beam	W10 x 17, Gr. 50		
One-Piece Cold-Formed Frame Rails	S		
Crossmembers	3" Jr I-beam		
Headboard (in/mm)	5.5 / 140		
Channel Side Rails (in/mm)	6 / 152		
Deck Material	2" nom. White Oak		
Tie Downs	D-rings		
Tie Downs (Total/Side)	8 / 4		
Beavertail (ft-in / mm) (angle-degrees)	5-0 / 1524 (14)		
Beavertail Type	Angle-Iron		
Ladder Style Ramps (ft-in x in/mm)	5-0 x 21 / 1524 x 533		
Off-the-Ground Spring Assist	S		

SUSPENSION / TIRES

Slipper Spring Suspension	S		
No. of Axles	2		
Axle Capacity (each) (lbs/kg)	8,000 / 3629		
Axle Spread (in/mm)	36 / 914		
Hubs	Standard Lube		
Electric Brakes w/Forward Adjust	S		
Battery Break-Away Kit w/Tow Charger	S		
Brake Size (in/mm)	12.25x3.38 / 311x86		
Wheels (in/mm)	17.5x6.75 / 445x171		
Wheel Bolt Pattern	8-bolt		
Tires / Load Range Rating	215/75R17.5 / H		

STANDARD EQUIPMENT

- Adjustable hitch height
- RV electrical plug
- Weather resistant sealed modular wiring
- Grommet mounted LED lights
- Registration holder
- Rust inhibiting primer
- Durable, rust inhibiting top coat
- Die-cut UV resistant vinyl decals
- D.O.T. approved conspicuity tape
- Mud flaps
- Adjustable ramp width spacing
- Trailer color: Equipment black
- Ramp color: Equipment Red

OPTIONAL EQUIPMENT

- 2-5/16 ball coupler
- Gooseneck
- 6-pole round electrical plug
- Storage tray lid
- 8K electric winch
- Additional tie-downs
- D-ring tie-downs
- E-Z Lube hubs
- Spare tire and wheel mount
- Spare tire and wheel
- Ramp lift springs
- Several ramp options
- Color options: Construction Yellow, Equipment Red, Blue, Charcoal
- Galvanizing



Other options may be available. Ask your dealer or visit our website.

*Payload capacity is calculated by taking the GVWR and subtracting the trailer weight. Listed GVWR, weights, and dimensions are for reference only. Manufacturer reserves the right to change models and specifications as they see fit. See our web site or your local authorized dealer for more information.