



### The Air Lock-Pin

Towmaster® detachable gooseneck trailers are standard with our air-pin lock attachment design. This is a stronger design for heavier loads and offers a decent hookup in a variety of conditions. The fit and finish is unmatched as the entire trailer is pre-painted before assembly and decking for a professional, clean look. Our detachable gooseneck is completely designed and built at our factory, so you can be sure you are getting genuine Towmaster® quality.



Hydraulic cylinders are encased in the uprights for a strong lift. Load blocks adjust ride height and are built into the uprights.



Air Pin design locks gooseneck to deck. The angled trough helps align the deck to the pin.



A stronger trunnion section allows the use of a flip-axle or booster to better distribute the load.

### Quick Specs:

- Variable ride height
- 8'-6" deck width
- Air-Pin deck hookup
- T1 steel deck
- Air brakes
- Ridewell® suspension
- Front flip-ramps
- Outriggers
- LED lights



Photos may show optional equipment.

## AMERICA'S BEST BUILT TRAILERS FOR PROFESSIONAL HAULERS



**800-462-4517**  
TOWMASTER.COM



GALVANIZING AVAILABLE



MORE MODELS • MORE OPTIONS • MORE CHOICES  
DROP-DECK • TILT BED • DECK-OVER • GOOSENECK • LOWBOY • HYDRAULIC TAIL

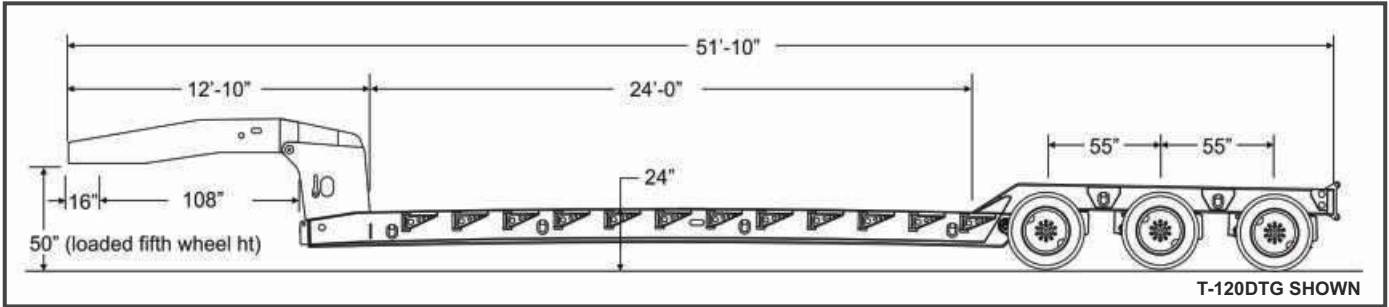

T-120DTG SHOWN

CAPACITY / DIMENSIONS		T-120DTG		
Capacity Rating (lbs/kg)	120,000 / 54,431			
Capacity Rating in 16ft (lbs/kg)	120,000 / 54,431			
Approx. Weight (lbs/kg)	19,500 / 8845			
Deck Height (fully loaded)(in/mm)	24 / 610			
Deck Length (ft-in/mm)	24-0 / 7315			
Overall Width (ft-in/mm)	8-6 / 2591			
Overall Length (ft-in/mm)	50-10 / 15,494			
GOOSENECK				
Length (ft-in/mm)	12-10 / 3912			
Swing Clearance (in/mm)	108 / 2743			
Fifth-Wheel Deck Lock	N/A			
Air-Pin Deck Lock	S			
Wet Line Hydraulic System	S			
Greaseable Pivot Points	S			
Twin Five-Position Load Blocks	S			
MAIN DECK / REAR TRUNNION				
Main Beam (T1 Flange) (in)	16 Fabricated			
Outside Rails (T1 Flange) (in)	14 Fabricated			
Diamond Cut-outs	O			
Crossmembers (Deep x Flange) (in)	10 x 4			
Outside Oak Deck Full 2"	S			
Self-Aligning Locking Fifth-Wheel	S			
Front Flip-up Ramps	S			
Fixed Approach	O			
Swing-out Outriggers	S			
HD Removable Swing-out Outriggers	O			
Tie Downs	Forged D-rings			
Number of Tie-Downs (Total / Side)	12 / 6			
Approach Bolster	S			
Supporting Bolsters Between Wheels	S			
Trunnion Open Boom Well	S			
Flip Axle Mount Brackets	S			
Stinger Reinforcement	O			
SUSPENSION / TIRES				
Air Suspension	S			
Meritor Axles (number of axles)	S (3)			
Axle Spread (in/mm)	55 / 1397			
Axle Capacity (each) (lbs/kg)	25,000 / 11,340			
Forged Alloy Spindles	S			
Oil Bath Hubs	S			
Air Brakes	S			
Brake Size (in/mm)	16.5x7 / 419x178			
22.5x8.25 Budd-type Wheels	S			
Wheels Hub Piloted	S			
Wheel Bolt Pattern	10-bolt			
Tire Size (all Load Range Rating H)	275/70R x 22.5			
Poly Mud Flaps	S			

**STANDARD EQUIPMENT**

- S.A.E. king pin set at 16"
- Weather resistant sealed modular wiring
- Grommet mounted LED lights
- Registration holder
- Rust inhibiting primer
- Durable, rust inhibiting top coat
- Die-cut UV resistant vinyl decals
- D.O.T. approved conspicuity tape
- Mud flaps
- Trailer color: Equipment black

**OPTIONAL EQUIPMENT**

- Longer swing-clearance lengths
- Gooseneck fenders
- Self-contained hydraulic unit
- Dual hydraulic system
- Tapered deck
- Additional deck length
- Wide deck
- Bucket plate
- Several ramp options
- Several wheel options
- Booster and Flip-Axle options
- Suspension and brake options
- Color options: Construction Yellow, Equipment Red, Blue, Charcoal



Other options may be available. Ask your dealer or visit our website.

\*Payload capacity is calculated by taking the GVWR and subtracting the trailer weight. Listed GVWR, weights, and dimensions are for reference only. Manufacturer reserves the right to change models and specifications as they see fit. See our web site or your local authorized dealer for more information.