



Our single-axle pan type tilt-deck trailers are designed for hauling small equipment. The T-5DT deck features white oak wood and 7-inch high sides. The low deck height offers a shallow tilt angle that allows small equipment to easily climb the incline. It features a rubber-ride axle, electric brakes, adjustable hitch, and a positive locking (over-center) latch system to safely keep the deck secured to the frame.



Positive locking (over-center) latch system keeps deck secured to the frame.



Grommet mounted LED lights are standard.



The "SL" (Scissor Lift) option included ramps to lower the loading incline.

#### Quick Specs:

- 2" nom. oak wood deck
- 14" deck height (loaded)
- 77" load width
- 12' or 14' deck
- EZ lube axles
- Forward self-adjusting electric brakes
- One-piece formed fender
- Low approach angle
- Grommet mounted LED lights

Photos may show optional equipment.

## PROFESSIONAL HAULERS DEMAND TOWMASTER



**800-462-4517**  
TOWMASTER.COM



MORE MODELS • MORE OPTIONS • MORE CHOICES  
DROP-DECK • TILT BED • DECK-OVER • GOOSENECK • LOWBOY • HYDRAULIC TAIL

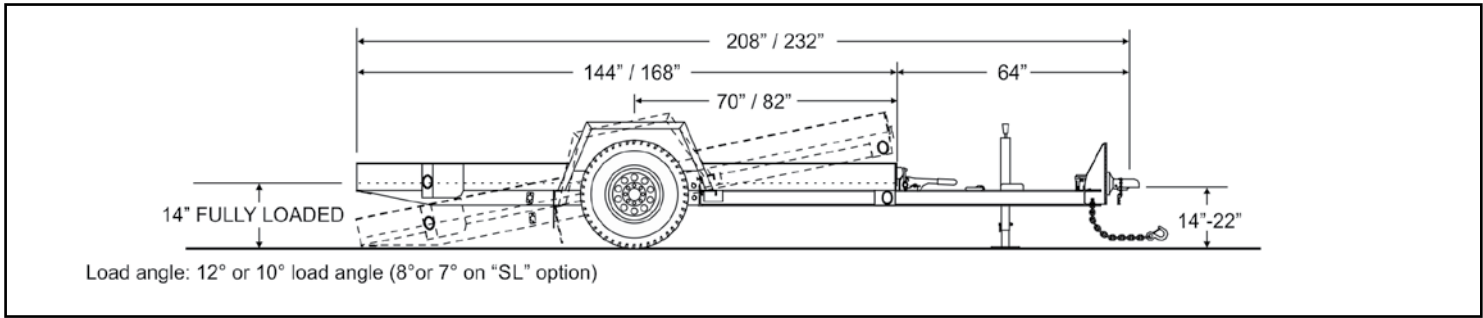

All dimensions are nominal. Illustration may be shown with optional equipment.

**Standard Features**

**Hitch/Tongue**

- Adjustable height, bolt-on coupler
- 2.5" pintle
- RV plug
- 7K bolt-on parking jack
- Battery break-away kit with tow charger & test light
- Safety chains with hooks

**Frame/Deck**

- 77" load width, 14" deck height (fully loaded)
- Single-point deck lock
- 4" I-beam main frame
- 3" Jr. I-beam crossmembers, 80,000 psi
- 2" nominal white oak wood deck
- 7" tall sides
- D-rings (3 per side)
- 12 ga one-piece formed fender/panel

**Ramps/Tail**

- 12°/10° load angle

**Axles/Suspension**

- Rubber-ride suspension axle
- (1) 7,000 lb. axle (2 wheels)
- Tires - 235/85R16 load range F
- 16" wheels, 8-bolt
- Electric brakes
- Forward self-adjusting brakes
- E-Z Lube hubs

**Lights/Wiring**

- Rubber grommet mounted LED lights
- Sealed modular wiring

**Standard Features**

- Limited Lifetime Frame Warranty
- One-Year full Warranty
- 10 Year Suspension Warranty
- Weatherproof registration holder
- Two-component polyurethane primer and paint
- Trailer color: Equipment Black

GAWR (lbs)	GVWR (lbs)	Weight (lbs)	Capacity (lbs)	Deck Width (in)	Deck Length (ft)
7,000	8,000	2,000	6,000	77"	12'
7,000	8,100	2,100	6,000	77"	14'

**Optional Equipment**

- Hydraulic surge brakes
- 3" pintle ring or 2-5/16" ball coupler
- Steel deck
- Deck cushion cylinder
- Additional tie-downs
- Spare tire and wheel
- Spare tire mount
- Tire upgrade, 235/85R16, 10 ply, G
- "SL" ramp option for hauling scissor lifts
- Color options: Construction Yellow, Equipment Red, Blue, Charcoal
- Galvanizing

Other options may be available. Ask your dealer or visit our website.

Listed GVWR, weights and dimensions are for reference only. Manufacturer reserves the right to change models and specifications as they see fit. See our web site or your local authorized dealer for more information.