



The Towmaster® T-50RG and T-70RG Rigid Gooseneck trailers are ready to haul your heavy equipment behind your fifth-wheel tractor. They feature dual axles, two-way spring-assist ramps, Hutchens® suspension and sealed wiring. A 10-foot top deck can haul a skid-loader or other smaller equipment (optional loading ramps required). A triple axle is available on the T-70RG.



S.A.E. King Pin with smooth approach plate for easy hook-up.



Wood protectors are standard on Towmaster T-series trailers and protect the end of the deck boards.



Two-way spring assist ramps allow you to easily lift ramps off deck and also off the ground. Grommet mounted LED lights are standard.

Quick Specs:

- 33" deck height (loaded)
- 8'-6" deck width
- 24' deck length, 10' top-deck
- Air brakes
- D-ring tie-downs
- Hutchens® suspension
- 5' angle-iron beavertail
- Two-way spring-assist ramps
- LED lights



Photos may show optional equipment.

AMERICA'S BEST BUILT TRAILERS FOR PROFESSIONAL HAULERS



800-462-4517
TOWMASTER.COM



**GALVANIZING
AVAILABLE**

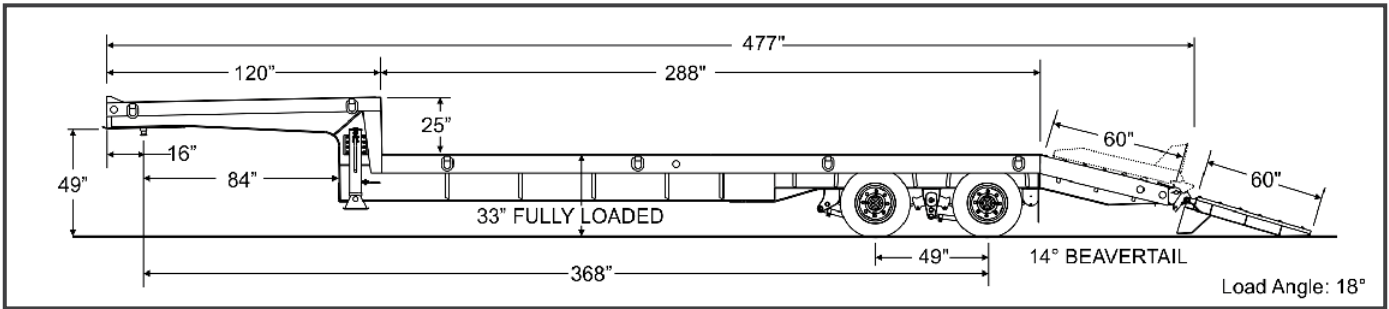

MORE MODELS • MORE OPTIONS • MORE CHOICES
DROP-DECK • TILT BED • DECK-OVER • GOOSENECK • LOWBOY • HYDRAULIC TAIL

SPECIFICATIONS
S=Standard O=Optional

CAPACITY / DIMENSIONS	T-50RG	T-70RG		
	Capacity Rating (lbs/kg)	50,000 / 22,680	70,000 / 31,751	
GVWR (lbs/kg)	61,500 / 27,896	85,600 / 38,827		
Approx. Weight (lbs/kg)	11,500 / 5216	15,600 / 7076		
Overall Length (ft-in/mm)	39-9 / 12,116	39-9 / 12,116		
Deck Height (loaded)(in/mm)	33 / 838	33 / 838		
Deck Length (ft-in/mm)	24-0 / 7315	24-0 / 7315		
Overall Width (ft-in/mm)	8-6 / 2591	8-6 / 2591		
GOOSENECK				
Top Deck Length (ft-in/mm)	10-0 / 3048	10-0 / 3048		
Swing Clearance (in/mm)	82.5 / 2096	82.5 / 2096		
Truck Height (in/mm)	49 / 1245	49 / 1245		
(2) Bolt-on Two-Speed Parking Jacks	25K	25K		
FRAME / RAMPS				
Main Beam (up to 24')	W16 x 26, Gr. 50	Mfg. Cambered		
Main Beam (25'+)	Mfg. Cambered	Mfg. Cambered		
Deck Crossmembers	3" Jr I-beam	6" I-beam		
Beam Crossmembers	N/A	W6 x 9, Gr. 50		
Channel Side Rails (in/mm)	8 / 203	8 / 203		
Deck Material	2" nom. White Oak	2" nom. White Oak		
Wood Protectors	S	S		
Forged D-Ring Tie Downs (total/Side)	12 / 6	12 / 6		
Beavertail (ft-in / mm) (angle-degrees)	5-0 / 1524 (14)	4-0 / 1219 (16)		
Ramps (ft-in x in/mm)	5-0 x 21 / 1524 x 533	5-0 x 21 / 1524 x 533		
Two-Way Spring Assist	S	S		
SUSPENSION / TIRES				
Hutchens Spring Suspension	S	S		
No. of Axles	2	2		
Axle Capacity (each) (lbs/kg)	22,500 / 10,206	22,500 / 10,206		
Axle Spread (in/mm)	49 / 1245	49 / 1245		
Hubs	Oil Bath	Oil Bath		
Brake Size (in/mm)	12.25x7.5 / 311x191	12.25x7.5 / 311x191		
Air Brakes (Full ABS Modulated, Park Brake All Axles)	S	S		
Hub Piloted Budd-type Wheels (in/mm)	17.5x6.75 / 445x171	17.5x6.75 / 445x171		
Wheel Bolt Pattern	8-bolt	8-bolt		
Tires / Load Range Rating	215/75R17.5 / H	235/75R17.5 / H		

STANDARD EQUIPMENT

- S.A.E. king pin
- 7-pole round electrical plug
- Weather resistant sealed modular wiring
- Grommet mounted LED lights
- Registration holder
- Rust inhibiting primer
- Durable, rust inhibiting top coat
- Die-cut UV resistant vinyl decals
- D.O.T. approved conspicuity tape
- Mud flaps
- Adjustable ramp width spacing
- Trailer color: Equipment black
- Ramp color: Equipment Red

OPTIONAL EQUIPMENT

- Sloped gooseneck
- Additional deck length
- 12K electric winch
- Additional tie-downs
- Rub rail with stake pockets
- Third axle (on T-70RG)
- Spare tire and wheel mount
- Spare tire and wheel
- Double-break beavertail (T-50RG)
- Several ramp options
- Color options: Construction Yellow, Equipment Red, Blue, Charcoal
- Galvanizing



Other options may be available. Ask your dealer or visit our website.

*Payload capacity is calculated by taking the GVWR and subtracting the trailer weight. Listed GVWR, weights, and dimensions are for reference only. Manufacturer reserves the right to change models and specifications as they see fit. See our web site or your local authorized dealer for more information.