



The Towmaster® deck-over tilt trailer offers convenience and durability. No ramps to hassle with, simply tilt the deck and drive on or off. Our patented automatic kick-out ramp doubles as under-ride protection. The deck is locked with a single-lever twin-latch system. A stationary forward deck is standard and a deck cushion cylinder eases the deck onto the frame.



Patented automatic kick-out ramp doubles as under-ride protection.



Cushion cylinder controls the deck tilt when loading or unloading equipment. Optional Hutchens® 9700 suspension shown.



4-foot stationary deck is standard and allows room for longer equipment and the added length makes towing easier.

### Quick Specs:

- 33" deck height (loaded)
- 8'-6" deck width
- 24' tilt deck, 4' stationary
- Air brakes
- D-ring tie-downs
- Hutchens® suspension
- Kick-out ramp/under-ride protection
- Single-lever twin-latch locking system
- LED lights



Photos may show optional equipment.

## AMERICA'S BEST BUILT TRAILERS FOR PROFESSIONAL HAULERS



**800-462-4517**  
TOWMASTER.COM



**GALVANIZING  
AVAILABLE**



MORE MODELS • MORE OPTIONS • MORE CHOICES  
DROP-DECK • TILT BED • DECK-OVER • GOOSENECK • LOWBOY • HYDRAULIC TAIL

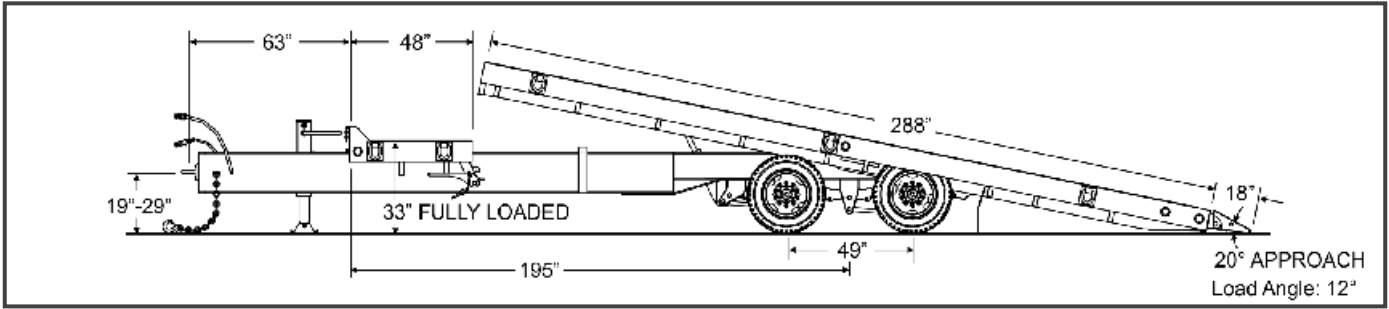

| CAPACITY / DIMENSIONS                                 |                     | SPECIFICATIONS        |  |  |
|---|---------------------|-----------------------|--|--|
|   |                     | S=Standard O=Optional |  |  |
|   |                     | T-40T                 |  |  |
| Payload Rating (lbs/kg)                               | 40,000 / 18,144     |                       |  |  |
| GVWR (lbs/kg)   | 50,500 / 22,906     |                       |  |  |
| GAWR (lbs/kg)   | 45,000 / 20,411     |                       |  |  |
| Approx. Avg. Weight (lbs/kg)                          | 10,500 / 4763       |                       |  |  |
| Overall Length (ft-in/mm)                             | 34-0 / 10,363       |                       |  |  |
| Deck Height (loaded)(in/mm)                           | 33 / 838            |                       |  |  |
| Overall Width (ft-in/mm)                              | 8-6 / 2591          |                       |  |  |
| TONGUE  |                     |                       |  |  |
| Tongue Length 5'-2" (1575mm)                          | S                   |                       |  |  |
| Storage Tray with Lid                                 | S                   |                       |  |  |
| Pintle Ring (in)                                      | 3                   |                       |  |  |
| High-Tensile Safety Chain                             | 1/2" Grade 80       |                       |  |  |
| Bolt-on Two-Speed Parking Jack                        | 25K                 |                       |  |  |
| FRAME / RAMPS   |                     |                       |  |  |
| Main Beam   | W16x26, Gr.50       |                       |  |  |
| One-Piece Cold-Formed Frame Rails                     | S                   |                       |  |  |
| Side Rails (in x in x in)                             | 8x2x1/4 Tubing      |                       |  |  |
| Crossmembers  | 3" Jr I-beam        |                       |  |  |
| Headboard Height (in/mm)                              | 5.5 / 140           |                       |  |  |
| Deck Length (ft/mm)                                   | 24+4 / 7315+1219    |                       |  |  |
| Deck Material   | 2" nom. White Oak   |                       |  |  |
| Deck Cushion Cylinder                                 | S                   |                       |  |  |
| Deck Latch  | Dual-Point          |                       |  |  |
| Approach Ramp (in x in/mm)                            | 18 / 457            |                       |  |  |
| Load Angle (degrees) – depending on deck length       | 10                  |                       |  |  |
| D-Ring Tie Downs (Total/Side)                         | 10 / 5              |                       |  |  |
| SUSPENSION / TIRES                                    |                     |                       |  |  |
| Adjustable Hutch 9700 Spring Suspension               | S                   |                       |  |  |
| No. of Axles  | 2                   |                       |  |  |
| Axle Capacity (each) (lbs/kg)                         | 22,500 / 10,206     |                       |  |  |
| Axle Spread (in/mm)                                   | 49 / 1245           |                       |  |  |
| Hubs  | Oil Bath            |                       |  |  |
| Brake Size (in/mm)                                    | 12.25x7.5 / 311x191 |                       |  |  |
| Air Brakes (Full ABS Modulated, Park Brake All Axles) | S                   |                       |  |  |
| Electric Brakes                                       | N/A                 |                       |  |  |
| Hub Piloted Budd Wheels (in/mm)                       | 17.5x6.75 / 445x171 |                       |  |  |
| Wheel Bolt Pattern                                    | 8-bolt              |                       |  |  |
| Tires / Load Range Rating                             | 235/75R17.5 / H     |                       |  |  |

**STANDARD EQUIPMENT**

- Adjustable hitch height
- 7-pole round electrical plug
- Weather resistant sealed modular wiring
- Grommet mounted LED lights
- Registration holder
- Rust inhibiting primer
- Durable, rust inhibiting top coat
- Die-cut UV resistant vinyl decals
- D.O.T. approved conspicuity tape
- Mud flaps
- Adjustable ramp width spacing
- Trailer color: Equipment black

**OPTIONAL EQUIPMENT**

- Rigid gooseneck
- Dual parking jacks
- Additional stationary deck length
- Additional tie-downs
- Tire upgrade (235/75R17.5)
- Spare tire and wheel mount
- Spare tire and wheel
- Color options: Construction Yellow, Equipment Red, Blue, Charcoal
- Galvanizing



Other options may be available. Ask your dealer or visit our website.

\*Payload capacity is calculated by taking the GVWR and subtracting the trailer weight. Listed GVWR, weights, and dimensions are for reference only. Manufacturer reserves the right to change models and specifications as they see fit. See our web site or your local authorized dealer for more information.