

T-3DT

Our single-axle pan type tilt-deck trailers are designed for hauling small equipment. The T-3DT is a steel deck with traction grit and 8-inch high sides. The low deck height offers a shallow tilt angle that allows small equipment to easily climb the incline. It features a rubber-ride axle, electric brakes, adjustable hitch, and a positive locking (over-center) latch system to safely keep the deck secured to the frame.



Positive locking (over-center) latch system keeps deck secured to the frame.



Grommet mounted LED lights are standard.



Sealed battery break-away system charges while plugged into the tow vehicle and can be checked at the press of a button.

Quick Specs:

- Steel pan deck
- 10' deck
- One-piece formed fender/inner panel
- 12.5" deck height (loaded)
- Dexter® Torflex® axles w/EZ Lube
- Low approach angle
- 54" load width
- Forward adjusting electric brakes
- Grommet mounted LED lights



Photos may show optional equipment.

AMERICA'S BEST BUILT TRAILERS FOR PROFESSIONAL HAULERS



800-462-4517
TOWMASTER.COM



MORE MODELS • MORE OPTIONS • MORE CHOICES
DROP-DECK • TILT BED • DECK-OVER • GOOSENECK • LOWBOY • HYDRAULIC TAIL

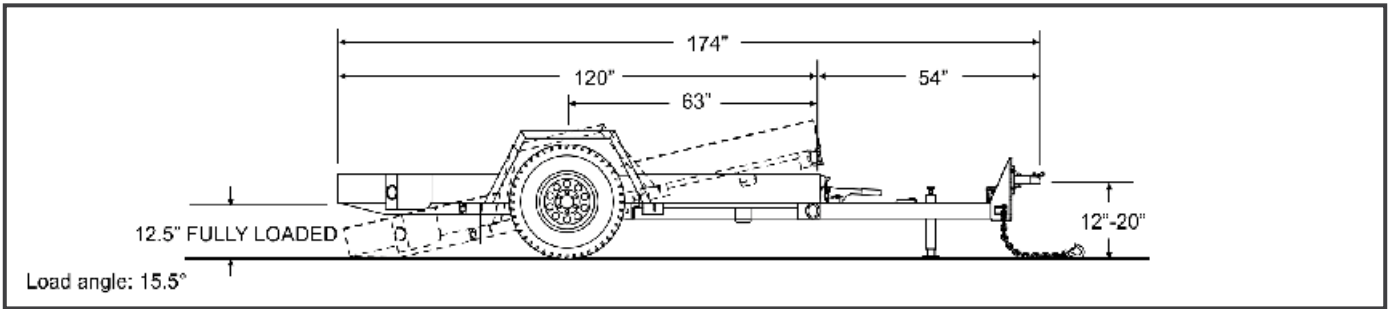

SPECIFICATIONS				
S=Standard O=Optional				
T-3DT				
CAPACITY / DIMENSIONS				
Payload Rating (lbs/kg)	3,500 / 1588			
GVWR (lbs/kg)	4,600 / 2086			
GAWR (lbs/kg)	3,500 / 1588			
Approx. Avg. Weight (lbs/kg)	1,100 / 499			
Overall Length (ft-in/mm)	14-6 / 4419			
Deck Height (loaded)(in/mm)	12.5 / 318			
Overall Width (in/mm)	80 / 2032			
Load Width (in/mm)	54 / 1372			
TONGUE				
Tongue Length 4'-6" (1372mm)	S			
Pintle Ring (in)	2.5			
Safety Chain	3/8" Grade 43			
Bolt-on Drop-Leg Parking Jack	5K			
FRAME / RAMPS				
Main Beam	4 x 2 Tubing			
Crossmembers	3" Jr I-beam			
Headboard Height (in / mm)	8 / 204			
Deck	Steel Pan			
Deck Lip (in / mm)	8 / 204			
Deck Latch	Single Point			
12 ga. One-piece formed fenders and inner panel	S			
Load Angle (degrees) – depending on deck length	14			
Tie Downs	D-ring			
Number of Tie-Downs (Total / Side)	6 / 3			
SUSPENSION / TIRES				
Rubber-Ride Axle w/Warranty	S			
Axle Capacity (each) (lbs/kg)	3,500 / 1588			
Axle Spread (in/mm)	N/A			
Hubs	E-Z Lube			
Electric Brakes w/Forward Adjust	S			
Brake Size (in/mm)	10x2.25 / 250x57			
Battery Break-Away Kit with Tow Charger	S			
Wheels (in/mm)	15x6 / 381x152			
Wheel Bolt Pattern	6-bolt			
Tires / Load Range Rating	225/75R15 / D			

STANDARD EQUIPMENT

- Adjustable hitch height
- RV electrical plug
- Weather resistant sealed modular wiring
- Grommet mounted LED lights
- Registration holder
- Rust inhibiting primer
- Durable, rust inhibiting top coat
- Die-cut UV resistant vinyl decals
- D.O.T. approved conspicuity tape
- Mud flaps
- Trailer color: Equipment black

OPTIONAL EQUIPMENT

- Hydraulic surge brakes
- 3" pintle ring or 2-5/16" ball coupler
- 6-pole round electrical plug
- Additional tie-downs
- Oak wood deck
- Deck cushion cylinder
- Rubber runner pads
- Spare tire and wheel
- Tire upgrades available on select models
- Color options: Construction Yellow, Equipment Red, Blue, Charcoal
- Galvanizing



Other options may be available. Ask your dealer or visit our website.

*Payload capacity is calculated by taking the GVWR and subtracting the trailer weight. Listed GVWR, weights, and dimensions are for reference only. Manufacturer reserves the right to change models and specifications as they see fit. See our web site or your local authorized dealer for more information.