



The premium line of Towmaster® deck-over trailers has proven to offer durability, longevity and style that other brands try to emulate. The T-30 offers the heaviest capacity with electric brakes. It's built on our famous I-Beam main frame with a 20-foot deck complete with rear wood protectors. It also features a self-cleaning angle iron beavertail, two-way spring-assist ramps, and LED lighting.



Wood protectors are standard on Towmaster T-series trailers. They protect the end of the deck boards as equipment is loaded.



Self-cleaning angle iron beavertail provides positive traction when loading equipment.



Two-way spring-assist ramps allow easy lifting of ramps off the deck and the ground. Grommet mounted LED lights are standard.

Quick Specs:

- 33.5" deck height (loaded)
- 8'-6" deck width
- 20' deck length
- Electric brakes
- Tool tray lid standard
- Hutchens® suspension
- Self-cleaning angle-iron beavertail
- Two-way spring-assist ramps
- LED lights and sealed wiring



Photos may show optional equipment.

AMERICA'S BEST BUILT TRAILERS FOR PROFESSIONAL HAULERS



800-462-4517
TOWMASTER.COM



GALVANIZING
AVAILABLE



MORE MODELS • MORE OPTIONS • MORE CHOICES
DROP-DECK • TILT BED • DECK-OVER • GOOSENECK • LOWBOY • HYDRAULIC TAIL

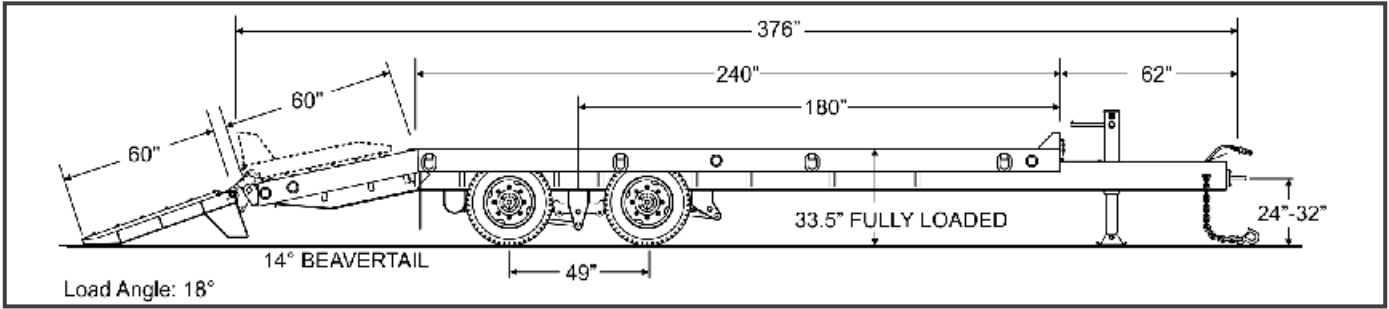

SPECIFICATIONS

S=Standard O=Optional
T-30

CAPACITY / DIMENSIONS

Capacity Rating (lbs/kg)	30,000 / 13,608		
GVWR (lbs/kg)	38,300 / 17,373		
GAWR (lbs/kg)	30,000 / 13,608		
Approx. Weight (lbs/kg)	8,300 / 3765		
Overall Length (ft-in/mm)	31-4 / 9550		
Deck Height (loaded)(in/mm)	33.5 / 851		
Deck Length (ft-in/mm)	20-0 / 6096		
Overall Width (ft-in/mm)	8-6 / 2591		

TONGUE

Tongue Length (ft-in/mm)	5-2 / 1575		
Storage Tray with Lid	S		
Pintle Ring (in)	S		
High-Tensile Safety Chain (size - in)	1/2 Grade 70		
Bolt-on Drop-Leg Parking Jack	25K		

FRAME / RAMPS

Main Beam	W10 x 26, Gr. 50		
One-Piece Cold-Formed Frame Rails	S		
Crossmembers	3" Jr I-beam		
Headboard (in/mm)	5.5 / 140		
Channel Side Rails (in/mm)	8 / 203		
Deck Material	2" nom. White Oak		
Wood Protectors	S		
Forged D-Ring Tie Downs (total/Side)	8 / 4		
Beavertail (ft-in / mm) (angle-degrees)	5-0 / 1524 (14)		
Ramps (ft-in x in/mm)	5-0 x 21 / 1524 x 533		
Two-Way Spring Assist	S		

SUSPENSION / TIRES

Hutchens Spring Suspension	S		
No. of Axles	2		
Axle Capacity (each) (lbs/kg)	15,000 / 6803		
Axle Spread (in/mm)	49 / 1245		
Hubs	Oil Bath		
Electric Brakes	S		
Brake Size (in/mm)	12.25x5 / 311x127		
Air Brakes (Full ABS Modulated, Park Brake All Axles)	N/A		
Hub Piloted Budd-type Wheels (in/mm)	17.5x6.75 / 445x171		
Wheel Bolt Pattern	8-bolt		
Tires / Load Range Rating	215/75R17.5 / H		

STANDARD EQUIPMENT

- Adjustable hitch height
- 7-pole round electrical plug
- Weather resistant sealed modular wiring
- Grommet mounted LED lights
- Registration holder
- Rust inhibiting primer
- Durable, rust inhibiting top coat
- Die-cut UV resistant vinyl decals
- D.O.T. approved conspicuity tape
- Mud flaps
- Trailer color: Equipment black
- Ramp color: Equipment Red

OPTIONAL EQUIPMENT

- Gooseneck
- 25K two-speed parking jack
- Dual parking jacks
- Additional deck length
- Additional tie-downs
- Rub rail with stake pockets
- 12K electric winch
- Spare tire and wheel mount
- Spare tire and wheel
- Double-break beavertail
- Several beavertail options
- Color options: Construction Yellow, Equipment Red, Blue, Charcoal
- Galvanizing



Other options may be available. Ask your dealer or visit our website.

*Payload capacity is calculated by taking the GVWR and subtracting the trailer weight. Listed GVWR, weights, and dimensions are for reference only. Manufacturer reserves the right to change models and specifications as they see fit. See our web site or your local authorized dealer for more information.