

## T-24TA / T-40TA / T-50TA



Low load angle

Towmaster's® deck-over air-tilt trailers offer convenience and easy loading by tilting the bed using air from the tow vehicle's system. This provides a clean and efficient way of tilting the deck without the use of hydraulics. Optional ramps can be manual or air-operated. Simply tilt the deck, drive on or off and level the deck back down. The tilt deck trailer features a single-lever twin-latch system to secure the deck to the frame. The low load angle allows for easy equipment loading and unloading.



Dual air-bag design uses air from the tow vehicle's system.



Standard approach ramp provides low approach angle for easy loading.



Optional 6-foot air ramps offer an even lower approach angle.

### Quick Specs:

- 32" deck height (loaded)
- 8'-6" deck width
- 24' (24TA, 40TA). 26' (50TA)
- Air brakes
- D-ring tie-downs
- Hutchens® suspension
- Dual air bag design
- Single-lever twin-latch locking system
- LED lights



Photos may show optional equipment.

## AMERICA'S BEST BUILT TRAILERS FOR PROFESSIONAL HAULERS



800-462-4517  
TOWMASTER.COM



GALVANIZING AVAILABLE



MORE MODELS • MORE OPTIONS • MORE CHOICES  
DROP-DECK • TILT BED • DECK-OVER • GOOSENECK • LOWBOY • HYDRAULIC TAIL

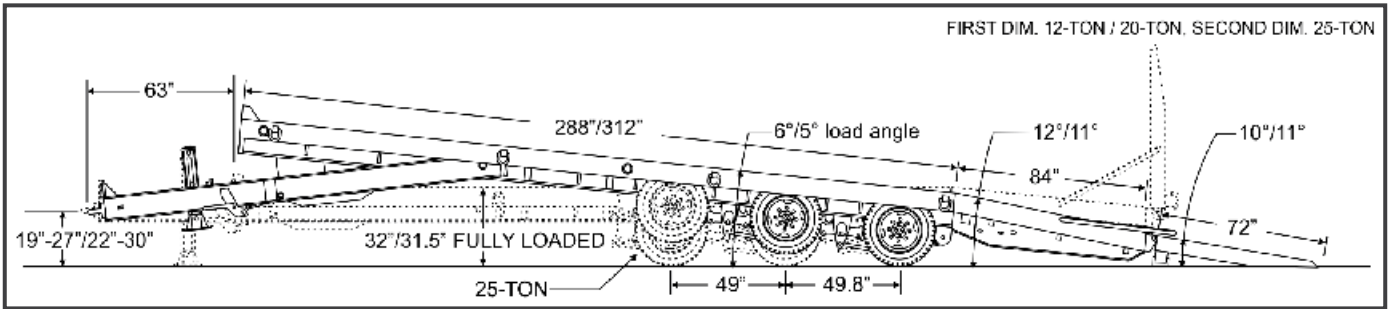

FIRST DIM. 12-TON / 20-TON, SECOND DIM. 25-TON

**SPECIFICATIONS**

S=Standard O=Optional

CAPACITY / DIMENSIONS	T-24TA	T-40TA	T-50TA
Payload Rating (lbs/kg)	24,000 / 10,886	40,000 / 18,143	50,000 / 22,679
GVWR (lbs/kg)	34,610 / 15,698	52,100 / 23,632	62,600 / 28,394
GAWR (lbs/kg)	24,000 / 10,886	45,000 / 20,411	54,480 / 24,711
Approx. Avg. Weight (lbs/kg)	10,610 / 4812	12,100 / 5488	12,600 / 5715
Overall Length (ft-in/mm)	36-6 / 11,125	36-6 / 11,125	38-6 / 11,734
Deck Height (loaded)(in/mm)	32 / 813	32 / 813	31.5 / 800
Overall Width (ft-in/mm)	8-6 / 2591	8-6 / 2591	8-6 / 2591
<b>TONGUE</b>			
Tongue Length 5'-3" (1600mm)	S	S	S
Storage Tray with Lid	S	S	S
Pintle Ring (in)	3	3	3
High-Tensile Safety Chain	1/2" Grade 70	1/2" Grade 80	5/8" Grade 80
Bolt-on Two-Speed Parking Jack	25K	25K	25K
<b>FRAME / RAMPS</b>			
Main Beam	W10x17, Gr.50	W10x26, Gr.50	W10x26, Gr.50
One-Piece Cold-Formed Frame Rails	S	S	S
Channel Side Rails	C8x11.5	C8x11.5	C8x11.5
Crossmembers	3" Jr I-beam	3" Jr I-beam	3" Jr I-beam
Headboard Height (in / mm)	5.5 / 140	5.5 / 140	5.5 / 140
Deck Length (ft/mm)	24 / 7315	24 / 7315	26 / 7924
Deck Material	2" nom. White Oak	2" nom. White Oak	2" nom. White Oak
Deck Latch	Dual-Point	Dual-Point	Dual-Point
Dual Air Bags (deck lift)	S	S	S
Approach Ramp (in x in/mm)	18 / 457	18 / 457	18 / 457
Load Angles – ramp, beavertail, deck (degrees)	10 / 12 / 6	10 / 12 / 6	11 / 11 / 5
D-Ring Tie Downs (Total / Side)	10 / 5	10 / 5	10 / 5
<b>SUSPENSION / TIRES</b>			
Slipper-spring Suspension	S	N/A	N/A
Hutchens 9700 suspension	O	S	S
Axle Capacity (each) (lbs/kg)	12,000 / 5443	22,500 / 10,206	22,500 / 10,206
Number of Axles	2	2	3
Axle Spread (in/mm)	49 / 1245	49 / 1245	49 / 1245
Hubs	Oil Bath	Oil Bath	Oil Bath
Air Brakes with full ABS	S	S	S
Brake Size (in/mm)	12.25x5 / 311x127	12.25x7.5 / 311x191	12.25x7.5 / 311x191
Wheels (in/mm)	16x6 / 406x152	17.5x6.75 / 445x171	17.5x6.75 / 445x171
Wheel Bolt Pattern	8-bolt	8-bolt	8-bolt
Tires / Load Range Rating	235/85R16 / E	235/75R17.5 / H	215/75R17.5 / H

**STANDARD EQUIPMENT**

- Adjustable hitch height
- 7-pole round electrical plug
- Weather resistant sealed modular wiring
- Grommet mounted LED lights
- Registration holder
- Rust inhibiting primer
- Durable, rust inhibiting top coat
- Die-cut UV resistant vinyl decals
- D.O.T. approved conspicuity tape
- Mud flaps
- Adjustable ramp width spacing
- Trailer color: Equipment black

**OPTIONAL EQUIPMENT**

- Gooseneck / rigid gooseneck
- Stake pockets
- 12K elec. winch
- Additional tie-downs
- Air or manual ramps
- Spare tire and wheel mount
- Spare tire and wheel
- Color options: Construction Yellow, Equipment Red, Blue, Charcoal
- Galvanizing



Other options may be available. Ask your dealer or visit our website.

\*Payload capacity is calculated by taking the GVWR and subtracting the trailer weight.  
 Listed GVWR, weights, and dimensions are for reference only. Manufacturer reserves the right to change models and specifications as they see fit. See our web site or your local authorized dealer for more information.