



The Towmaster® deck-over tilt trailers offer convenience and durability. No ramps to hassle with, simply tilt the deck and drive on or off. It features our patented automatic kick-out ramp that doubles as under-ride protection, a single-lever twin-latch system, stationary forward deck, Hutchens® suspension, and a deck cushion cylinder to ease the deck up and down.



Patented automatic kick-out ramp doubles as under-ride protection.



Cushion cylinder controls the deck tilt when loading or unloading equipment. Optional Hutchens® 9700 suspension shown.



4-foot stationary deck is standard and allows room for longer equipment and the added length makes towing easier.

Quick Specs:

- 34" deck height (loaded)
- 8'-6" deck width
- 24' tilt deck, 4' stationary
- Electric or air brakes
- D-ring tie-downs
- Hutchens® suspension
- Kick-out ramp/under-ride protection
- Single-lever twin-latch locking system
- LED lights



Photos may show optional equipment.

AMERICA'S BEST BUILT TRAILERS FOR PROFESSIONAL HAULERS



800-462-4517
TOWMASTER.COM



**GALVANIZING
AVAILABLE**



MORE MODELS • MORE OPTIONS • MORE CHOICES
DROP-DECK • TILT BED • DECK-OVER • GOOSENECK • LOWBOY • HYDRAULIC TAIL

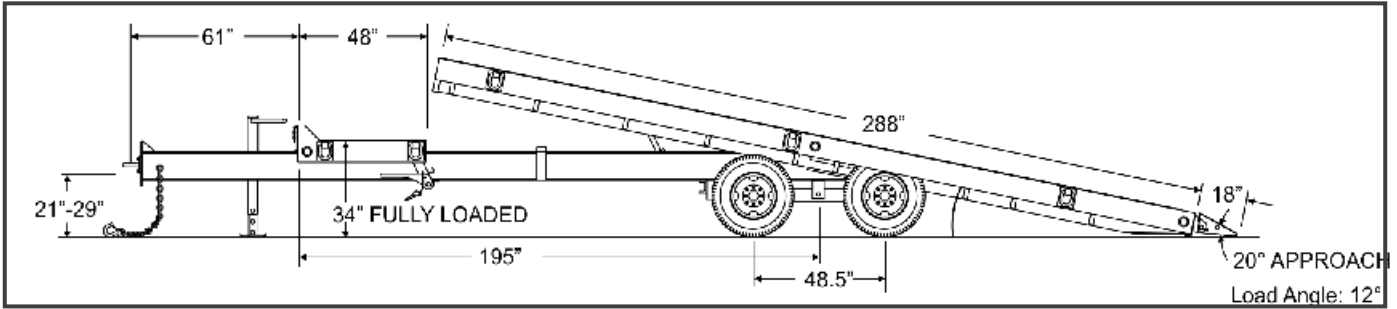

SPECIFICATIONS

S=Standard O=Optional

CAPACITY / DIMENSIONS	T-20T		T-24T	
	Payload Rating (lbs/kg)	17,300 / 7847	24,000 / 10,886	
GVWR (lbs/kg)	25,990 / 11,789	32,690 / 14,827		
GAWR (lbs/kg)	20,000 / 9072	24,000 / 10,886		
Approx. Avg. Weight (lbs/kg)	8,690 / 3942	8,690 / 3942		
Overall Length (ft-in/mm)	34-8 / 10,566	34-8 / 10,566		
Deck Height (loaded)(in/mm)	34 / 864	34 / 864		
Overall Width (ft-in/mm)	8-6 / 2591	8-6 / 2591		
TONGUE				
Tongue Length 5'-2" (1575mm)	S	S		
Storage Tray with Lid	S	S		
Pintle Ring (in)	3	3		
High-Tensile Safety Chain	3/8" Grade 70	1/2" Grade 70		
Bolt-on Two-Speed Parking Jack	12K	12K		
FRAME / RAMPS				
Main Beam	W10x17, Gr.50	W10x17, Gr.50		
One-Piece Cold-Formed Frame Rails	S	S		
Side Rails (in x in x in)	8x2x3/16 Tubing	8x2x3/16 Tubing		
Crossmembers	3" Jr I-beam	3" Jr I-beam		
Headboard Height (in / mm)	5.5 / 140	5.5 / 140		
Deck Length (ft/mm)	24+4 / 7315+1219	24+4 / 7315+1219		
Deck Material	2" nom. White Oak	2" nom. White Oak		
Deck Cushion Cylinder	S	S		
Deck Latch	Dual-Point	Dual-Point		
Approach Ramp (in x in/mm)	18 / 457	18 / 457		
Load Angle (degrees)	10	10		
D-Ring Tie Downs (Total / Side)	10 / 5	10 / 5		
SUSPENSION / TIRES				
Slipper-spring suspension	S	S		
Adjustable Hutch 9700 Spring Suspension	O	O		
Axle Capacity (each) (lbs/kg)	10,000 / 4536	12,000 / 5443		
Axle Spread (in/mm)	49 / 1245	49 / 1245		
Hubs	Oil Bath	Oil Bath		
Brake Size (in/mm)	12.25x4 / 311x102	12.25x5 / 311x127		
Electric Brakes w/Battery Break-Away Kit and Charger	S	S		
Air Brakes (Full ABS Modulated, Park Brake All Axles)	O	O		
Hub Piloted Budd Wheels (in/mm)	16x6 / 406x152	16x6 / 406x152		
Wheel Bolt Pattern	8-bolt	8-bolt		
Tires / Load Range Rating	235/85R16 / E	235/85R16 / E		

STANDARD EQUIPMENT

- Adjustable hitch height
- 7-pole round electrical plug
- Weather resistant sealed modular wiring
- Grommet mounted LED lights
- Registration holder
- Rust inhibiting primer
- Durable, rust inhibiting top coat
- Die-cut UV resistant vinyl decals
- D.O.T. approved conspicuity tape
- Mud flaps
- Adjustable ramp width spacing
- Trailer color: Equipment black

OPTIONAL EQUIPMENT

- Gooseneck
- Additional stationary deck length
- 6-pole round electrical plug
- Additional tie-downs
- Spare tire and wheel mount
- Spare tire and wheel
- Color options: Construction Yellow, Equipment Red, Blue, Charcoal
- Galvanizing



Other options may be available. Ask your dealer or visit our website.

*Payload capacity is calculated by taking the GVWR and subtracting the trailer weight. Listed GVWR, weights, and dimensions are for reference only. Manufacturer reserves the right to change models and specifications as they see fit. See our web site or your local authorized dealer for more information.